

#### CAUTION

All cleaning and maintenance should be carried out when the pizza oven is cool and with the fuel supply turned OFF at the gas cylinder.

#### TO CHECK FOR LEAKS

If you smell gas: (In the event of gas leakage found).

Turn off the gas supply at the gas cylinder valve.

Ensure the control valve is "OFF".

Connect the regulator to the cylinder and ON/OFF valve to the burner, ensure the connections are secure then turn ON the gas.

Brush the soapy water onto the hose and all joints. If bubbles appear you have a leak, which must be rectified before use.

Retest after fixing the fault.

Turn off the gas supply at the gas container after use.

If leakage is detected again and cannot be rectified. Do not attempt to cure leakage but consult your gas dealer.

#### STORAGE

Store the pizza oven out of direct sunlight and indoors where possible and when storing for extended periods of time, storage is only permissible if the cylinder is disconnected and removed from the pizza oven. The pizza oven should not be exposed to harsh weather conditions such as snow, heavy rain and strong winds. It should be stored in its original packaging and stored in a dry dust free environment.

Wait for the pizza oven to cool completely before moving.

#### PIZZA BAKING STONE

1. DO NOT use the stone over an open flame.
2. Avoid extreme temperature change to the stone. DO NOT place frozen foods on a hot stone.
3. The stone is fragile and can break if bumped or dropped.
4. The stone is very hot during use and stays hot for a long time after use.
5. DO NOT cool the stone with water when the stone is hot.
6. After cleaning the stone with water, please dry the stone before use. This can be done in a conventional oven at 60°C (140°F) for 2 hours.

#### CARE

Apart from cleaning, your gas pizza oven is a fairly low maintenance item. A couple of things are worth looking at through. Remember to turn off and disconnect the gas before any maintenance is carried out.

1. If your gas pizza oven uses a flexible hose to connect to the gas, check the rubber O-ring on the regulator end of the hose assembly at least once a year. If it appears worn or cracked, have it replaced.
2. If you use a portable LPG gas cylinder, you will need to have the cylinder serviced or replaced every ten years. The date of the last service should be stamped on the neck of the bottle.
3. A rain cover is also recommended to cover your gas pizza oven and maintain and protect from all weather conditions.

#### MAINTENANCE

1. Keeping appliance area clear and free from combustible materials, gasoline, and other flammable vapors and liquids.
2. Not obstructing the flow of combustion and ventilation air.
3. Keeping the ventilation opening(s) of the cylinder enclosure free and clear from debris.
4. Cleaning appliance, including special surfaces, with recommended cleaning agents if necessary.
5. Checking and cleaning burner tubes for insects and insect nests. A clogged tube can lead to a fire beneath the appliance.

Your pizza oven will look better and last longer if you keep it clean.

If instructions or parts are missing contact [www.oliverscraft.co](http://www.oliverscraft.co) for assistance.

### Warranty & Returns

#### OPENING HOURS

Mon - Fri: 8am - 5pm

Closed On Public Holidays

27 Proton Cres, Triangle Farm, Cape Town, 7530

## GPO-SA0102 InfernoX Gas Pizza Oven Manual & Safety Instructions

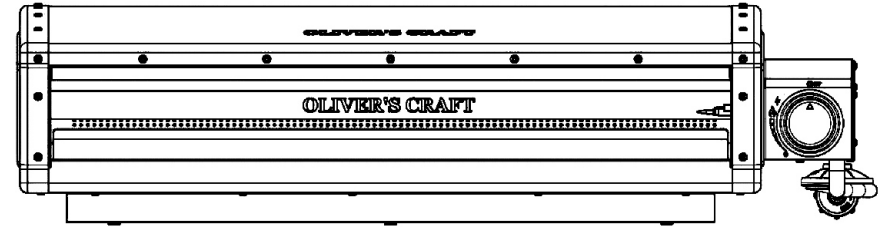

#### WARNING

Whilst every effort has made in manufacture of your pizza oven to remove any sharp edge, you should handle all components with care to avoid accidental injury.

**Tools may required:** Either a Philips crosshead or flat-bladed screwdriver and either a spanner or a pair pliers.

The primary air intake adjuster is factory-set and cannot be fully closed by the user (as required by test method 8.6(b)).

A SANS 1237-approved regulator with an outlet pressure of 2.8 kPa.

#### ASSEMBLY

Please read all instructions thoroughly before proceeding. Find a large, clean area in which to assemble your gas pizza oven. Please refer to the parts list and assembly diagram as necessary.

#### NOTICE

Make sure all the plastic protection rip off before assembling!

#### DANGER

**Never operate this appliance unattended. If a fire should occur, keep away from the appliance and immediately call your fire department.**

**Do not attempt to extinguish an oil or a grease fire with water.**

If you smell gas

- Shut off gas to the appliance.
- Extinguish any open flame.
- If odor continues, keep away from the appliance and immediately call your gas supplier or your fire department.
- Failure to follow these instructions could result in fire, explosion or burn hazard which could cause property damage, personal injury or death.

## BEFORE USE

Inspect the gas supply hose prior to turning on the gas. If there is evidence of cut, wear or abrasion, it must be replaced prior to use.

Screw the regulator onto the gas cylinder. Leak check the hose and regulator connections with a soap and water solution before lighting the appliance.

Only the pressure regulator and gas hose assembly supplied with this appliance should be used.

### LP GAS CYLINDER WARNING

1. Do not store spare liquid propane gas cylinder under or near this appliance.
2. Never fill the cylinder beyond 80% capacity.
3. Liquid propane cylinder must be fitted with an OVERFILL PROTECTION DEVICE (OPD).
4. If the information above is not followed exactly, a fire resulting in death or serious injury may occur.
5. This manual states that the installation must conform with local codes.

## SAFETY PRACTICES TO AVOID INJURY

When properly cared for, your oven will provide safe, reliable service for many years. However, extreme care must be used as the oven produces intense heat that can increase the risk of accidents.

When using this oven basic practices must be followed, including but not limited to following:

- Do not repair or replace any part of the oven unless specifically recommended in this manual. All other service should be referred to a qualified technician.
- Children should not be left alone or unattended in an area where the oven is being used. Do not allow children to sit, stand or play around the oven at any time.
- Never let clothing or other flammables come in contact with or too close to any burner or hot surface until it has cooled. The fabric could ignite, causing serious personal injury.
- For personal safety, wear proper apparel. Loose fittings garments or sleeves should never be worn while using the oven. Some synthetic fabrics are highly flammable and should not be worn while cooking.
- Do not heat unopened food containers as a build-up of pressure may cause the containers to burst. When lighting the burner, always pay close attention to what you are doing.
- When using the oven, do not touch the outer shell, stone baking board or immediate surroundings as these areas become extremely hot and could cause burns.
- Do not use the oven to cook extremely fatty meats or other products which increase flare-up.
- Keep the area surrounding the oven free from combustible material including fluids, trash and vapours such as gasoline or charcoal lighter fluid.
- Do not obstruct the flow of combustion and ventilation air.
- Never use the oven in extremely windy conditions.
- The temperature under the oven is high. Do not place the oven on a table with flammable table cloths, plastic or any

## PARTS LIST

- 1 x PIZZA OVEN
- 2 x PIZZA STONES
- 2 x PIZZA SPADES
- 1 x OUTDOOR COVER
- 1 x GAS HOSE WITH PRESSURE REGULATOR

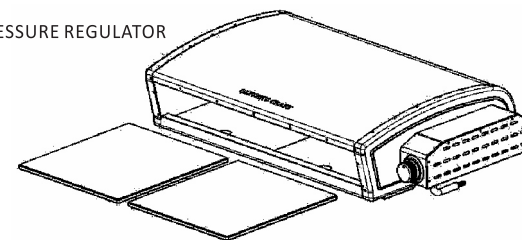

## ASSEMBLY

Before assembly, please make sure all parts are present. If any part is missing or damaged, do not attempt to assemble the appliance. Contact customer service for replacement parts.

### 1. Insert the InfernoX Ceramic Pizza Stone

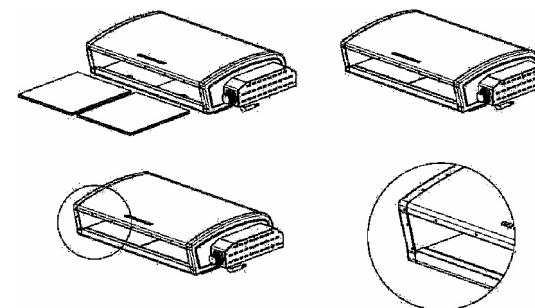

### 2. Take out the InfernoX Ceramic Pizza Stone

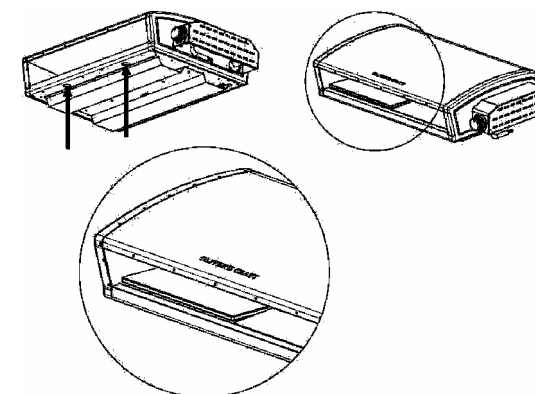

### 3. Connecting gas regulator and hose to pizza oven

Please note the factory setting that the regulator and hose has been assembled to the pizza oven.

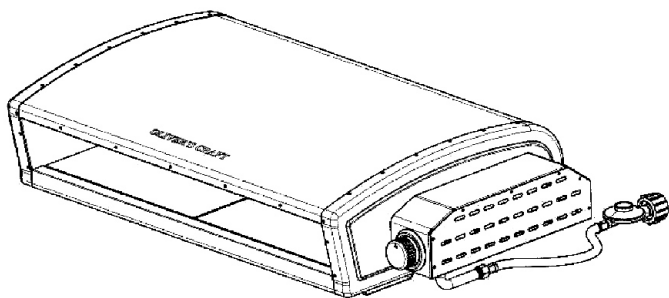

### 4. Connecting to gas tank

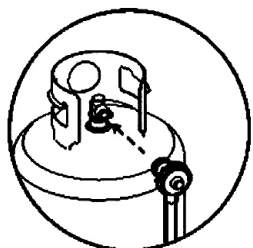

#### WARNING

- Please always keep the gas bottle in upright position.
- The maximum size of the gas cylinder should be: Dia. 320mm, Height: 600 mm.
- If the appliance is not in use, the gas must be turned OFF at the supply cylinder.
- The cylinder used must include a collar to protect the cylinder valve.
- The minimum distance for the appliance and the gas tank is 1m apart.
- This gas fitting is clockwise. Make sure that the tank is completely switched OFF and screw the regulator as far as possible into the gas tank valve.
- Changing the gas container which shall be carried out away from any source of ignition.

#### CONNECTING THE LIQUID PROPANE GAS CYLINDER

1. To connect the liquid propane gas cylinder:
2. The cylinder valve should be in OFF position.
3. Make sure the burner valve is in OFF position.
4. Inspect the valve connections, port and regulator assembly. Remove debris and inspect the hose for damage.
5. When connecting the regulator assembly to the valve, use your hand to tighten the nut clockwise until it stops. Use of a wrench could damage the quick coupling nut and result in a hazardous situation.
6. Open the cylinder valve fully by turning the valve counterclockwise.
7. Before lighting the oven, use a soap and water solution to check all connections for leaks.
8. If a leak is found, turn the cylinder valve OFF, and do not use the oven until local liquid propane dealer can make repairs.

#### CONNECTING THE LIQUID PROPANE GAS CYLINDER

1. Turn the oven burner valve OFF and make sure the oven is cool.
2. Turn the liquid propane cylinder valve OFF by turning clockwise until it stops.
3. Detach the regulator assembly from the cylinder valve by turning the quick coupling nut counterclockwise.
4. Place dust cap for cylinder valve outlet whenever the cylinder is not in use.
5. The cylinder supply system must be arranged for vapor withdrawal.

#### IMPORTANT

Read the following instructions carefully and be sure your gas pizza oven is properly installed, assembled and cared for. Failure to follow these instructions may result in serious bodily injury and/or property damage.

If you have any questions concerning assembly or operation, consult your dealer or LPG Gas Company. When used on the ground always place the appliance and cylinder on flat level ground.

Your gas pizza oven can be used with gas cylinders between 11 kg and 15 kg. The maximum size of the gas cylinder should be: Dia. 320mm, Height: 600 mm. Follow the technical information as stated in the instruction manual and Check with your local gas supplier to have a suitable gas cylinder for your pizza oven.

#### NOTE FOR CONSUMER: Retain for future Reference

#### CONNECTING THE GAS CYLINDER TO THE APPLIANCE

This appliance is only suitable for use with low-pressure butane or propane gas or LPG mixtures, fitted with the appropriate low-pressure regulator via a flexible hose.

The hose should be secured to the regulator and the appliance with hose clips. Make sure the flexible hose could not come in contact with hot surface and avoid twisting.

Use a suitable regulator that is certified to BSEN 12864 or EN 16129. Make sure the regulator and flexible hose comply with local code.

Please consult your LPG dealer for information regarding a suitable regulator for the gas cylinder.

#### Regulator and Hose

Use only regulators and hose approved for LP Gas at the above pressures. The life expectancy of the regulator is estimated as 2 years.

The use of the wrong regulator or hose is unsafe; always check that you have the correct items before operating the appliance.

The hose used must conform to the relevant standard for the country of use. Worn or damaged hose must be replaced. Ensure that the hose is not obstructed, kinked, or in contact with any part of the appliance other than at its connection.

#### For Flexible hose

Avoid twisting the flexible tube when the appliance is in use. The length of flexible hose shall not exceed 1.5m. In Finland, the length shall not exceed 1.2m. The hose should be certified according to applicable EN Standard and comply with local code.

#### Gas Cylinder

The gas cylinder should not be dropped or handled roughly! If the appliance is not in use, the cylinder must be disconnected. Replace the protective cap on the cylinder after disconnecting the cylinder from the appliance. The gas cylinder must be sited outside the body of the appliance.

Always connect or replace the cylinder in a well-ventilated area and away from any source of ignition, never in the presence of a flame, spark or heat source. Cylinders must be stored outdoors in an upright position and out of the reach of children. The cylinder must never be stored where temperatures can reach over 50°C. Do not store the cylinder near flames, pilot lights or other sources of ignition. **DO NOT SMOKE.**

This gas pizza oven is designed for use outdoors, away from any flammable materials. It is important that there are no overhead obstructions and that there is a minimum distance of 1m from the side or rear of the appliance. It is important that the ventilation openings of the appliance are not obstructed. The appliance must be used on a level, stable surface. The appliance should be protected from direct draughts and shall be positioned or protected against direct penetration by any trickling water (e.g rain).

**Parts sealed by the manufacturer or his agent must not be altered by the user. No modifications should be made to any part of this pizza oven and repairs and maintenance should only be carried out by a registered service engineer.**

#### Connection to Appliance

Before connection, ensure that there is no debris caught in the head of the gas cylinder, regulator, burner and burner ports. Spiders and insects can nest within and clog the burner/venturi tube at the orifice. A clogged burner can lead to a fire beneath the appliance.

Fit the hose to the appliance using a spanner to tighten it onto the connection thread. If the hose is replaced it must be secured to the appliance and regulator connections with hose clips. Disconnect the regulator from the cylinder (according to the directions supplied with the regulator) when the appliance is not in use.

The appliance must be used in a well ventilated area. Do not obstruct the flow of combustion air to the burner when the appliance is in use.

**ONLY USE THIS GAS PIZZA OVEN OUTDOORS.**

## LEAK TESTING

### BEFORE USE CHECK FOR LEAKS

Never check for leaks with a naked flame, always use a soapy water solution

### TO CHECK FOR LEAKS

Make 2-3 fluid ounces of leak detecting solution by mixing one part washing up liquid with 3 parts water.

Ensure the control valve is "OFF".

Connect the regulator to the cylinder and ON/OFF valve to the burner, ensure the connections are secure then turn ON the gas.

Brush the soapy solution onto the hose and all joints. If bubbles appear you have a leak, which must be rectified before use.

Retest after fixing the fault.

Turn OFF the gas at the cylinder after testing.

If leakage is detected and cannot be rectified. Do not attempt to cure leakage but consult your gas dealer.

### GENERAL

Although the gas connections of the appliance are leak tested prior packing and shipment, a complete test must be performed at the installation site.

Before each use, check all the gas connections for leak testing using the procedure listed below. If the smell of gas is detected at any time, you should immediately stop using and check the entire system for leaks.

### BEFORE TESTING

Make sure all packing material has been removed from the appliance.

Make a solution of one part liquid detergent and one part water. You will need a spray bottle, brush or rag to apply the solution to the fittings.

### TO TEST

1. Turn the burner valve OFF
2. Turn the liquid propane cylinder valve on counterclockwise to open the valve.
3. Apply the soap solution to all gas fittings. Soap bubbles would appear where a leak is present.
4. If a leak is present, immediately turn the gas supply OFF and tighten leaky fittings.
5. Turn the gas back ON and recheck.
6. Should the gas continue to leak from any of the fittings, turn the gas supply OFF and contact customer service.

## OPERATING INSTRUCTIONS - USING THE PIZZA OVEN

To begin:

1. Make sure the pizza oven has been leak tested and properly placed.
2. Remove any remaining packing material.
3. Light the burner using the LIGHTING INSTRUCTIONS below.

### LIGHTING AND ADJUST THE FIRE INSTRUCTION

1. Ensure well ventilation before lighting the burner.
2. Before use please make sure the control knob is in the "OFF" position. Then push the control knob and slowly turn the knob anticlockwise to "HI" position for 5 seconds until you hear a click and the burner ignites ( A). If not repeat this process.
3. You can adjust the fire from "HI" to "LOW" by slowly turn the control knob clockwise (B)
4. Please turn the control knob to "HI" position, then push the knob and clockwise to "OFF" position to turn off your pizza (C)
5. If the burner has not lit after retrying wait 5 minutes and repeat step 2.

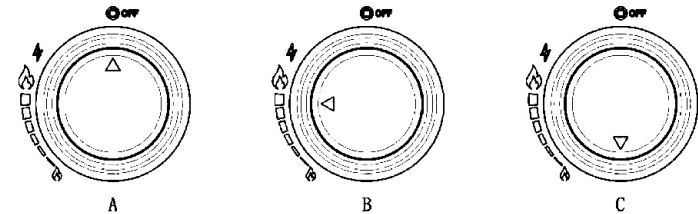

### LIGHTING BY MATCH

1. If burner will not light after several attempts using the control knob, the burner may be lit with a match. And must be waiting few minutes for any gas to dissipate before lighting by match.
2. Make sure the knob is in the "OFF" position.
3. Push down the knob and keep pressing whilst turning anti-clockwise to the "HIGH" position (a clicking sound is heard). Insert a match into the matchstick holder and put the lighted match near the ports of the burner, this will light the burner. Observe if the burner has lit. If not repeat this process.
4. If the burner has not lit after retrying, must be turn the control knob "OFF" and wait 5 minutes and repeat step 3.
5. Adjust the heat by turning the knob to the High/Low position.
6. To turn the pizza oven "OFF" turn the cylinder valve or regulator switch to the "OFF" position and then turn the control knob on the appliance clockwise to the "OFF" position.

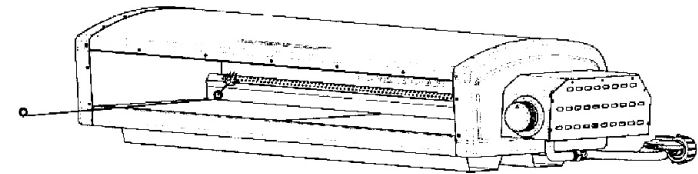

### WARNING

If the burner fails to ignite, turn the control knob off (clockwise) and also turn the cylinder valve off. Wait five minutes before attempting to relight with ignition sequence.

Before cooking for the first time, operate the pizza oven for about 15 minutes and the gas turned on LOW. This will "heat clean" the internal parts and dissipate odour from the painted finish.

### AFTER COOKING

To turn the gas pizza oven off, it is best to turn off the cylinder first, and allow all the gas remaining in the hose to burn off, this will only take a couple of seconds. Then turn off burner.

While the pizza oven is cool down, then remove the pizza stone and stock it well for next using.

It is recommended that protective gloves (e.g. oven gloves) be used when handling particularly hot components.

## TROUBLESHOOTING

PROBLEM	SOLUTION
Burner doesn't light	<ol style="list-style-type: none"> <li>1. Check and to see if your propane tank is empty.</li> <li>2. Turn the coupling nut about one half to three quarters additional turn until sold stop. Tighten by hand only, please do not use tools.</li> <li>3. Clean the burner tube.</li> <li>4. Reengage burner and valve.</li> <li>5. Check steps in assembly instructions.</li> </ol>
Low flame or gas flow dropped suddenly	<ol style="list-style-type: none"> <li>1. Check your propane tank.</li> <li>2. Turn off gas control knob, wait for 1 min and light oven. If the flame still low, turn off gas control knob and propane tank valve. Disconnect and Reconnect regulator and leak test. Turn on propane tank valve, wait for 30s and then light the oven.</li> </ol>
Flames blow out	<ol style="list-style-type: none"> <li>1. Move oven away from the wind.</li> <li>2. Refill the propane tank.</li> </ol>
Flare-up	<ol style="list-style-type: none"> <li>1. May grease build up, please clean oven.</li> <li>2. May excessive fat in meat, please trim fats from meat before cooking.</li> <li>3. May excessive temperature, please adjust temperature accordingly.</li> <li>4. May excess flour on the cooking surface, please clean the remain flour from cooking surface.</li> </ol>
Flashback	<ol style="list-style-type: none"> <li>1. May burner or burner tubes are blocked, please turn gas control knob off and clean burner or burner tubes.</li> <li>2. May pressure drop during ignition, please turn off pizza oven, make sure the tank valve is fully open.</li> </ol>

Manufacturer	OLIVERS FOOD (PTY) LTD
Address	10 Fisant St, Sonstraal, Durbanville, Western Cape, 7550, South Africa
Model	GPO-SA0102
Appliance	InfernoX Gas Pizza Oven
Gas Category	13+(28-30/37)
Gas Type	Butane/Propane
Gas Pressure	28-30/37 mbar
Total Nominal Heat Input	8.5 kW (G30: 619 g/h, G31: 608 g/h)
Destination Countries	BE, FR, IT, LU, IE, GB, GR, PT, ES, CY, CZ, LT, SK, CH, SI and LV
Orifice Size	1.45mm



**2531-25**  
**2531-GAR-CGC11475**  
 PIN Code: 2531DP-0203  
 S/N: JXYEAR/MONTH/DAY/XXX  
**Use outdoors only.**  
 Read the instructions before using the appliance.  
**WARNING**  
 Accessible parts may be very hot. Keep young children away.  
 Do not use spirit or petrol for lighting or re-lighting.  
**DESIGNED IN SOUTH AFRICA**  
**MADE IN CHINA**